

# SHURE®

LEGENDARY  
PERFORMANCE™

Professional Wireless  
Bodypack Receiver

# P3RA USER GUIDE

Le Guide de l'Utilisateur

Bedienungsanleitung

Manuale d'uso

Guia del Usuario

Guida dell'Utente

Руководство пользователя

Gebruikershandleiding

Pengguna Panduan

ユーザーガイド

사용자 안내서

用戶指南

取扱説明書



© 2017 Shure Incorporated  
27A24540 (rev. 2)  
Printed in China





# IMPORTANT SAFETY INSTRUCTIONS

1. READ these instructions.
2. KEEP these instructions.
3. HEED all warnings.
4. FOLLOW all instructions.
5. DO NOT use this apparatus near water.
6. CLEAN ONLY with dry cloth.
7. DO NOT block any ventilation openings. Allow sufficient distances for adequate ventilation and install in accordance with the manufacturer's instructions.
8. DO NOT install near any heat sources such as open flames, radiators, heat registers, stoves, or other apparatus (including amplifiers) that produce heat. Do not place any open flame sources on the product.
9. DO NOT defeat the safety purpose of the polarized or grounding type plug. A polarized plug has two blades with one wider than the other. A grounding type plug has two blades and a third grounding prong. The wider blade or the third prong are provided for your safety. If the provided plug does not fit into your outlet, consult an electrician for replacement of the obsolete outlet.
10. PROTECT the power cord from being walked on or pinched, particularly at plugs, convenience receptacles, and the point where they exit from the apparatus.
11. ONLY USE attachments/accessories specified by the manufacturer.
12. USE only with a cart, stand, tripod, bracket, or table specified by the manufacturer, or sold with the apparatus. When a cart is used, use caution when moving the cart/apparatus combination to avoid injury from tip-over. 
13. UNPLUG this apparatus during lightning storms or when unused for long periods of time.
14. REFER all servicing to qualified service personnel. Servicing is required when the apparatus has been damaged in any way, such as power supply cord or plug is damaged, liquid has been spilled or objects have fallen into the apparatus, the apparatus has been exposed to rain or moisture, does not operate normally, or has been dropped.
15. DO NOT expose the apparatus to dripping and splashing. DO NOT put objects filled with liquids, such as vases, on the apparatus.
16. The MAINS plug or an appliance coupler shall remain readily operable.
17. The airborne noise of the Apparatus does not exceed 70dB (A).
18. Apparatus with CLASS I construction shall be connected to a MAINS socket outlet with a protective earthing connection.
19. To reduce the risk of fire or electric shock, do not expose this apparatus to rain or moisture.
20. Do not attempt to modify this product. Doing so could result in personal injury and/or product failure.
21. Operate this product within its specified operating temperature range.

**WARNING:** This product contains a chemical known to the State of California to cause cancer and birth defects or other reproductive harm.

## 低功率電波輻射性電機管理辦法

### 第十二條

經型式認證合格之低功率射頻電機，非經許可，公司、商號或使用者均不得擅自變更頻率、加大功率或變更原設計之特性及功能。第十四條

低功率射頻電機之使用不得影響飛航安全及干擾合法通信；經發現有干擾現象時，應立即停用，並改善至無干擾時方得繼續使用。前項合法通信，指依電信法規定作業之無線電通信。低功率射頻電機須忍受合法通信或工業、科學及醫療用電波輻射性電機設備之干擾。

## WARNING

- Battery packs may explode or release toxic materials. Risk of fire or burns. Do not open, crush, modify, disassemble, heat above 140°F (60°C), or incinerate.
- Follow instructions from manufacturer
- Only use Shure charger to recharge Shure rechargeable batteries
- **WARNING:** Danger of explosion if battery incorrectly replaced. Replace only with same or equivalent type.
- Never put batteries in mouth. If swallowed, contact your physician or local poison control center
- Do not short circuit; may cause burns or catch fire
- Do not charge or use battery packs other than Shure rechargeable batteries
- Dispose of battery packs properly. Check with local vendor for proper disposal of used battery packs.
- Batteries (battery pack or batteries installed) shall not be exposed to excessive heat such as sunshine, fire or the like

**WARNING:** Danger of explosion if incorrect battery replaced. Operate only with AA batteries.

## SAFETY PRECAUTIONS

The possible results of incorrect use are marked by one of the two symbols—"WARNING" and "CAUTION"—depending on the imminence of the danger and the severity of the damage.



**WARNING:** Ignoring these warnings may cause severe injury or death as a result of incorrect operation.



**CAUTION:** Ignoring these cautions may cause moderate injury or property damage as a result of incorrect operation.

## CAUTION

- Never disassemble or modify the device, as failures may result.
- Do not subject to extreme force and do not pull on the cable or failures may result.
- Keep the product dry and avoid exposure to extreme temperatures and humidity.

## WARNING

- If water or other foreign objects enter the inside of the device, fire or electric shock may result.
- Do not attempt to modify this product. Doing so could result in personal injury and/or product failure.

This device is able to produce sound volume higher than 85 dB SPL. Please check your maximum allowed continuous noise exposure level based on your national employment protection requirements.

## WARNING

**LISTENING TO AUDIO AT EXCESSIVE VOLUMES CAN CAUSE PERMANENT HEARING DAMAGE. USE AS LOW A VOLUME AS POSSIBLE.** Over exposure to excessive sound levels can damage your ears resulting in permanent noise-induced hearing loss (NIHL). Please use the following guidelines established by the Occupational Safety Health Administration (OSHA) on maximum time exposure to sound pressure levels before hearing damage occurs.

<b>90 dB SPL</b> at 8 hours	<b>95 dB SPL</b> at 4 hours	<b>100 dB SPL</b> at 2 hours	<b>105 dB SPL</b> at 1 hour
<b>110 dB SPL</b> at ½ hour	<b>115 dB SPL</b> at 15 minutes	<b>120 dB SPL</b> Avoid or damage may occur	

---

## Important Product Information

---

### LICENSING INFORMATION

Licensing: A ministerial license to operate this equipment may be required in certain areas. Consult your national authority for possible requirements. Changes or modifications not expressly approved by Shure Incorporated could void your authority to operate the equipment. Licensing of Shure wireless microphone equipment is the user's responsibility, and licensability depends on the user's classification and application, and on the selected frequency. Shure strongly urges the user to contact the appropriate telecommunications authority concerning proper licensing, and before choosing and ordering frequencies.

## Information to the user

This equipment has been tested and found to comply with the limits for a Class B digital device, pursuant to Part 15 of the FCC Rules. These limits are designed to provide reasonable protection against harmful interference in a residential installation. This equipment generates uses and can radiate radio frequency energy and, if not installed and used in accordance with the instructions, may cause harmful interference to radio communications. However, there is no guarantee that interference will not occur in a particular installation. If this equipment does cause harmful interference to radio or television reception, which can be determined by turning the equipment off and on, the user is encouraged to try to correct the interference by one or more of the following measures:

- Reorient or relocate the receiving antenna.
- Increase the separation between the equipment and the receiver.
- Connect the equipment to an outlet on a circuit different from that to which the receiver is connected.
- Consult the dealer or an experienced radio/TV technician for help.

**Industry Canada ICES-003 Compliance Label:** CAN ICES-3 (B)/NMB-3(B)

**Note:** EMC conformance testing is based on the use of supplied and recommended cable types. The use of other cable types may degrade EMC performance.

**Changes or modifications not expressly approved by the manufacturer could void the user's authority to operate the equipment.**

Please follow your regional recycling scheme for batteries, packaging, and electronic waste.

The antenna(s) must be installed such that a minimum separation distance of 20 cm is maintained between the radiator (antenna) and all persons at all times.

La ou les antennes doivent être installées de telle façon qu'une distance de séparation minimum de 20 cm soit maintenue entre le radiateur (antenne) et toute personne à tout moment.

### Australia Warning for Wireless

This device operates under an ACMA class licence and must comply with all the conditions of that licence including operating frequencies. Before 31 December 2014, this device will comply if it is operated in the 520-820 MHz frequency band. **WARNING:** After 31 December 2014, in order to comply, this device must not be operated in the 694-820 MHz band.

## General Description

The Shure P3RA bodypack receiver works with Shure P3T transmitters as part of the PSM300® stereo personal monitoring system. An advanced user menu featuring an LCD display delivers increased functionality over the standard PSM300 bodypack receiver, while an all-metal housing provides superior durability. Compatibility with the Shure SB900 rechargeable battery delivers improved battery life and provides an environmentally friendly way to save money and reduce waste.

For more information on using the P3RA with the PSM300 system, refer to the PSM300 user guide (included with the transmitter and available at [shure.com](http://shure.com)).

## P3RA Bodypack

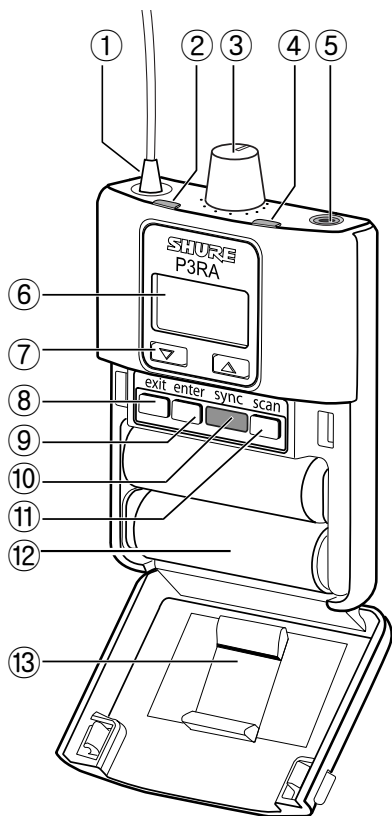

### ① Antenna

Receives signal from P3T transmitter

### ② RF Indicator

Illuminates when the bodypack is receiving a signal from the transmitter

### ③ Volume Knob / Power Switch

Turn to power on/off and adjust headphone volume

### ④ Battery LED

Indicates battery status

Note: see the battery life table for specific run-time values

### ⑤ Headphone Output

Use earphones or headphones with a 3.5 mm (1/8-inch) plug

### ⑥ Display

Shows settings and menu navigation

### ⑦ Navigation buttons (▲▼)

Use to scroll through menu and adjust settings

### ⑧ Exit button

Press to return to previous screen

### ⑨ Enter button

Press to enter a menu screen or to confirm a setting

### ⑩ IR Sync Window

Use to send group and channel settings between the bodypack and transmitter

### ⑪ Scan Button

Press to perform an RF scan

### ⑫ Battery Compartment

Uses a Shure SB900 rechargeable battery or two AA batteries

### ⑬ Removable AA Adapter

Remove to use with a Shure SB900 rechargeable battery

**Note:** To remove, open the door and slide the adapter out. To reinstall, press the adapter into place—there is an audible click when seated.

---

## Audio Settings

---

### MODE

**STEREO:** Audio from channel 1 is heard on the left earphone; audio from channel 2 is on the right earphone.

**MIXMODE:** Both channels are heard on the left and right earphones. The blend between mixes is adjustable.

### EQ

Use the two-band shelving equalizer to boost either bass or treble frequencies up to +6dB in 2 dB increments.

**LOWBOOST:** Boosts frequencies below 100 Hz

**HIGHBOOST:** Boosts frequencies above 10 kHz

**OFF:** No EQ (flat)

### VLIMIT (Maximum Volume)

Set a value (-3 to -21 dB, adjustable in 3 dB increments) to attenuate the highest possible volume level. Turning the volume knob through its entire range of motion still affects volume; the limit simply narrows the range of dB adjustment.

**Note:** The VLIMIT does **not** compress the audio.

### BAL MX / BAL ST (Balance)

The behavior of the balance control depends on which mode the bodypack is set to:

**STEREO:** Adjusts the left/right balance

**MIXMODE:** Adjusts the blend between channel 1 and channel 2

---

## Utilities

---

### CONTRAST

Customize the display screen contrast by selecting a setting between low and high

### LOCK PANEL

Locks all controls except the volume knob to prevent accidental changes to settings

**Lock:** Select **UTILITIES > LOCK PANEL**

**Unlock:** Press the exit button and select OFF when the lock setting screen appears. Press enter to confirm.

### BATTERY

Displays remaining battery runtime (hours:minutes), temperature, status, cycle count, health, and voltage

**Note:** Applies to SB900 battery only

### RESTORE

Restores bodypack to factory default settings

### AUTOOFF

Automatically turns off the bodypack after a selectable amount of time (5, 30, or 60 min.) while it is in power-save mode or when connected to a charger with the power on. To restore power to the bodypack, the power switch must be turned off and then on again.

**Note:** SB900 batteries charge fastest when the bodypack is off

---

## RF Settings

---

The **RADIO** menu contains selectable **GROUP** and **CHANNEL** settings, which are used to manually synchronize the receiver with the transmitter.

The frequency and band are displayed below the group and channel settings for reference.

# MixMode and Stereo Monitoring

The bodypack can operate in either of the following listening modes:

## Stereo (default)

To operate in stereo mode, enter the menu and select **AUDIO > MODE > STEREO**.

In stereo mode, audio from channel 1 is heard on the left earphone, while audio from channel 2 is heard on the right earphone. Listening in stereo increases clarity and separation between the sources on each channel.

## Adjusting Balance

To adjust the left/right balance, select **AUDIO > BAL ST**. Use the **▲▼** buttons to change the setting.

## MixMode

To operate in MixMode, enter the menu and select **AUDIO > MODE > MIXMODE**.

In MixMode, the blend between two monitoring mixes (an instrumental mix and a vocal mix, for example) is adjustable. The signal is mono, which means each mix is heard through both the left and right earphones.

## Adjusting mix blend

To adjust the blend between channel 1 and channel 2, enter the menu and select **AUDIO > BAL MX**. Use the arrow buttons (**▲▼**) to make adjustments.

In this scenario, an instrumental mix is on channel 1 (left) and a vocal mix is on channel 2 (right):

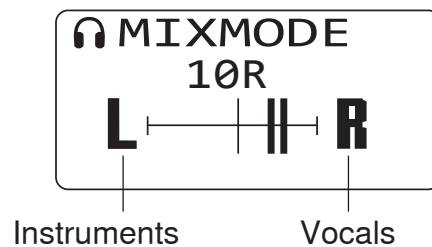
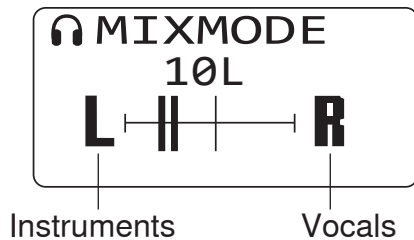

To hear more of channel one (instruments), shift the balance towards the left.

To hear more of channel two (vocals), shift the balance towards the right.

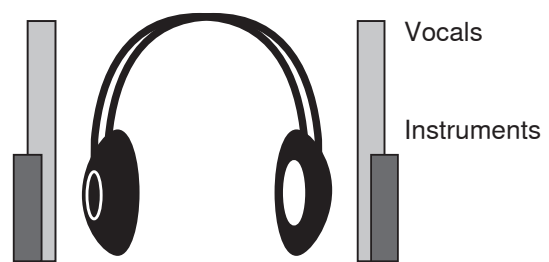
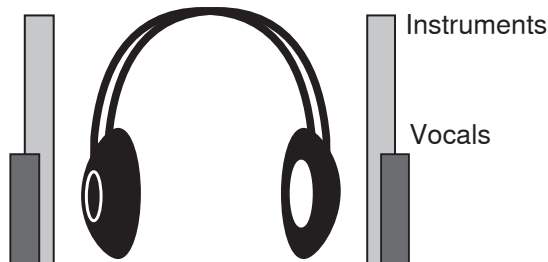

## Balance and Mix Adjustments from the Home Screen

To make quick adjustments to the stereo balance or MixMode blend, use the arrow buttons (**▲▼**) while in the home screen. If necessary, use the lock feature to prevent any accidental adjustments.

# Shure SB900 Rechargeable Battery

Shure SB900 lithium-ion batteries offer a rechargeable option for powering the bodypack. Batteries quickly charge to 50% capacity in one hour and reach full charge within three hours.

Single chargers and multiple bay chargers are available to recharge the Shure batteries.

**Caution:** Only charge Shure rechargeable batteries with a Shure battery charger.

## Single Bay Charger

The SBC-100 single bay charger offers a compact charging solution.

1. Plug the charger into an AC power source or USB port.
2. Insert a battery into the charging bay.
3. Monitor the charging status LEDs until charging is complete.

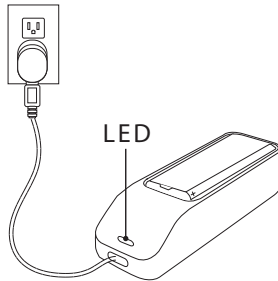

### Charging Status LED

Color	Status
Red	Charging
Green	Charging Complete
Amber Flashing	Fault: check connections and battery
Off	No battery in bay

## Multiple Bay Chargers

Shure offers three models of multiple bay chargers:

- SBC200 two bay charger
- SBC210 two bay charger
- SBC800 eight bay charger

SBC200 chargers can charge individual batteries or batteries installed in bodypacks.

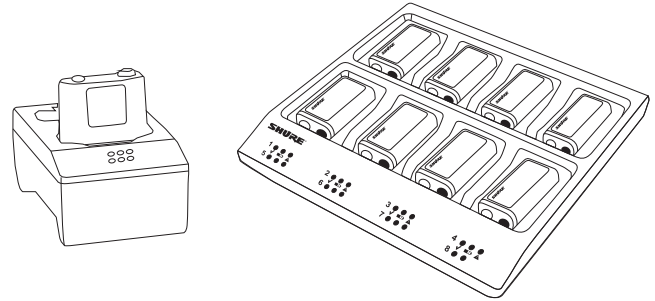

1. Plug the charger into an AC power source.
2. Insert batteries or bodypacks into the charging bay.
3. Monitor the charging status LEDs until charging is complete.

### Charging Status LED

Color	Status
Green	Charging Complete
Green/Red	Charge level above 90%
Red	Charging
Amber Flashing	Fault: check connections and battery
Off	No battery in bay







## Important Tips for Care and Storage of Shure Rechargeable Batteries

Proper care and storage of Shure batteries results in reliable performance and ensures a long lifetime.

- Always store batteries and bodypacks at room temperature
- Ideally, batteries should be charged to approximately 40% of capacity for long-term storage
- During storage, check batteries every 6 months and recharge to 40% of capacity as needed



## Battery Life

Battery Indicator	Tri-Color Battery LED	Approximate Hours Remaining (h:mm)	
		Alkaline	Shure SB900 Rechargeable Battery
	Green	5:30 to 4:25	7:00 to 5:35
	Green	4:25 to 3:20	5:35 to 4:10
	Green	3:20 to 2:10	4:10 to 2:50
	Green	2:10 to 1:05	2:50 to 1:25
	Amber	1:05 to 0:30	1:25 to 0:40
	Red	< 0:30	< 0:40
Total Battery Life		5:30	7:00

**Note:** Battery life using Energizer™ brand AA Alkaline batteries and the following conditions:

- Receiver audio set to **EQ = OFF**, **VLIMIT = OFF**
- Audio output at bodypack: Pink noise at 100 dB SPL in ear with SE112 earphones (impedance at 20 Ω)

**Power-save mode:** When there are no earphones plugged in for 5 minutes, the receiver enters power-save mode to preserve battery life. The LED slowly fades on/off in this mode and continues to display the color that represents the remaining battery life.

## Optional Accessories and Replacement Parts

Shure Lithium-Ion Rechargeable Battery	SB900
AA battery adapter	65A15224
Dynamic MicroDriver earphones	SE112
Dynamic MicroDriver earphones	SE215
High-definition MicroDriver earphones with tuned bass port	SE315
High-definition earphones with dual MicroDrivers	SE425
High-definition earphones with triple MicroDrivers	SE535
High-definition earphones with quad MicroDrivers	SE846
Power a SB900-compatible bodypack with an AC power supply instead of batteriesDC Power Insert (Battery Eliminator)	SBC-DC

## Specifications

### Audio Frequency Response

38 Hz–15 kHz

### Operating Range

*environment dependent*

90 m (300 ft)

### Active RF Sensitivity

at 20 dB SINAD

2.2 μV

### Active RF Gain Control

20 dB

Adjusts RF sensitivity to provide more RF dynamic range

### Image Rejection

>90 dB

### Adjacent Channel Rejection

>60 dB

### Intermodulation Attenuation

>50 dB

### Blocking

>60 dB

### Audio Output Power

1kHz @ <1% distortion, peak power, @32Ω

80 mW (driving two channels)

### Output Impedance

<2.5 Ω

### Minimum Load Impedance

4 Ω

### Headphone Output

3.5 mm (1/8") stereo

### Low Shelf

2 dB Step Size

Selectable: -6 to +6 dB @ 100 Hz

### High Shelf

2 dB Step Size

Selectable: -6 to +6 dB @ 10 kHz

### Volume Limiter

3 dB Step Size

Selectable: -3 to -21 dB

### Net Weight

196 g(6.6 oz.) (with batteries)

### Dimensions

99 x 66 x 23 mm H x W x D

### Battery Life

*continuous use*

AA batteries	5.5 hours
SB900	7 hours

### Operating Temperature

-18°C to +63°C

## Certifications

This product meets the Essential Requirements of all relevant European directives and is eligible for CE marking.

Meets essential requirements of the following European Directives:

- Low Voltage Directive 2006/95/EC
- R&TTE Directive 99/5/EC
- WEEE Directive 2002/96/EC, as amended by 2008/34/EC
- RoHS Directive 2002/95/EC, as amended by 2008/35/EC

**Note:** Please follow your regional recycling scheme for batteries and electronic waste

Conforms to the relevant requirements of regulation (EC) No.278/2009, for low voltage external power supplies.

Meets requirements of the following standards:

EN 300 422 Parts 1 and 2. EN 301 489 Parts 1 and 9.

The CE Declaration of Conformity can be obtained from: [www.shure.com/europe/compliance](http://www.shure.com/europe/compliance)

Authorized European representative:  
Shure Europe GmbH  
Headquarters Europe, Middle East & Africa  
Department: EMEA Approval  
Jakob-Dieffenbacher-Str. 12  
75031 Eppingen, Germany  
Phone: 49-7262-92 49 0  
Fax: 49-7262-92 49 11 4  
Email: [info@shure.de](mailto:info@shure.de)

## P3RA

Approved under the Declaration of Conformity (DoC) provision of FCC Part 15.

Complies with requirements set out in RSS-GEN.

**Industry Canada ICES-003 Compliance Label:** CAN ICES-3 (B)/NMB-3(B)

This device complies with Industry Canada licence-exempt RSS standard(s). Operation of this device is subject to the following two conditions: (1) this device may not cause interference, and (2) this device must accept any interference, including interference that may cause undesired operation of the device.

Le présent appareil est conforme aux CNR d'Industrie Canada applicables aux appareils radio exempts de licence. L'exploitation est autorisée aux deux conditions suivantes : (1) l'appareil ne doit pas produire de brouillage, et (2) l'utilisateur de l'appareil doit accepter tout brouillage radioélectrique subi, même si le brouillage est susceptible d'en compromettre le fonctionnement.